

Installation of Digi-Star Scale System for Models 1050 and 1150 Grain Carts Equipped with Walking Tandem Dual Wheels

HITCH ASSEMBLY

1. Remove the 2 1/2" x 13 1/4" shaft from the swivel hitch by unbolting the 1" x 5 1/2" Grade 5 bolt and locknut that attaches the swivel hitch and the 1" x 4 1/2" Grade 5 bolt and locknut that attaches the rear collar.
2. Remove the eight 3/4" x 3" Grade 8 Bolts from the Hitch Spool Plate Support located on the front of the A-Frame.
3. Bolt the Weigh Bar Weldment to the threaded holes located on the rear of the A-Frame using four 3/4" x 3" Grade 8 bolts.
4. Reuse the 1" x 5 1/2" Grade 5 bolt and locknut to secure the Hitch Weigh Bar to the hitch.
5. Before installing the Hitch Weigh Bar, feed the wire through the left side of the A-Frame tubing and exit the frame through the hole located directly behind the front leg of the grain cart.
6. Slide the rear of the Hitch Weigh Bar through the Weigh Bar Weldment and secure using the 1" x 4 1/2" Grade 5 bolt and locknut. **NOTE:** Be sure the hitch weigh bar is secured in the UP position as indicated by the decal on the weigh bar.

HITCH PARTS

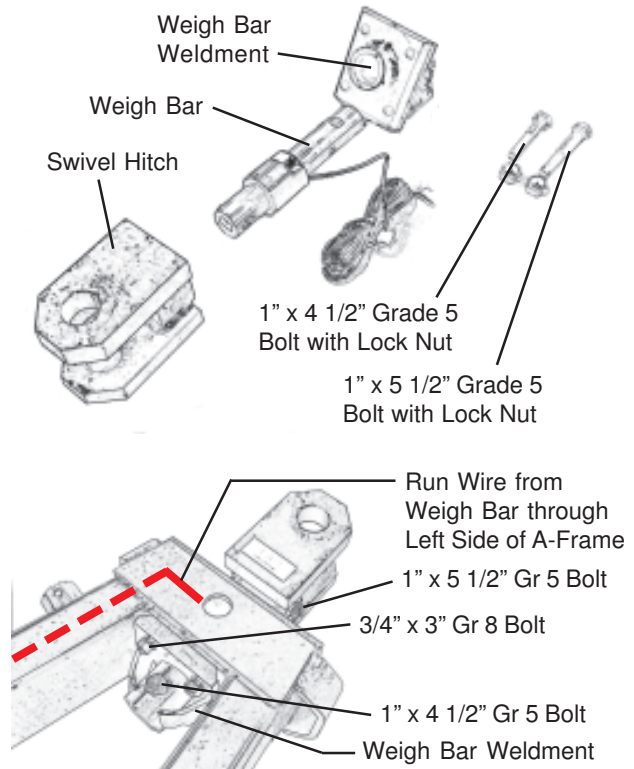

SPINDLE ASSEMBLY

1. With the cart empty, place a 10-ton jack and jack stands under the axle, near the tire to support the weight of the grain cart.
2. Remove the wheel & tire and hub assembly from the spindle. Remove the 1" x 7" hex bolt and lock nut located on the stock end of the spindle. Slide the spindle out from the A-Frame of the grain cart.
3. Run the wire on the weigh spindle through the tubing of the A-Frame toward the front leg of the grain cart where the Scale Indicator will be mounted. Insert the Adapter Pipe Tubing and Weigh Spindle into the cross axle frame of the grain cart and secure using the 5/8" x 6 1/2" Grade 5 bolt and lock nut. Be sure the weigh spindle is secured with the "TOP" decal facing up.
4. Re-attach the hub to the weigh spindle. (Note: Depending on the model and year of grain cart, the seal in the hub may also need to be changed.)
5. Attach the tire and wheel assembly. Be sure to tighten the lug nuts to proper torque setting.
6. Repeat steps 1 through 5 for other side.

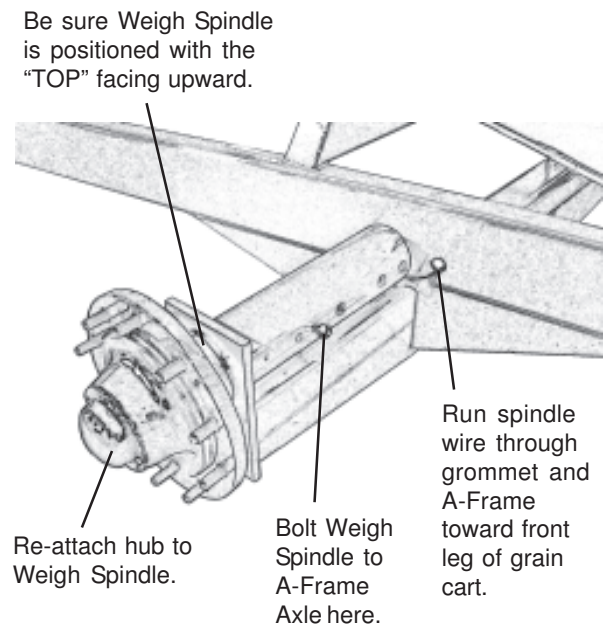

Installation of Digi-Star Scale System for Models 1050 and 1150 Grain Carts Equipped with Walking Tandem Dual Wheels

MOUNTING THE JUNCTION BOX

- Using the Junction Box as a template, mark and drill holes on the inside face of the front left side leg of the grain cart. The Junction Box should be positioned approximately 23" above the tubing of the A-Frame.
- After the holes have been drilled, secure the Junction Box to the inside of the front left leg of the grain cart using four #10 bolts and nuts.
- Remove the cover from the Junction Box. Insert the Hitch Weigh Bar wire through the center port and connect to the center terminal of the Junction Box by matching the colored wires. Repeat for the left and right side weigh spindle wires.
- Connect the J-Box cable between the center terminal and the indicator located on the front of the grain cart leg.
- Replace cover on Junction Box

Use Junction Box as a template to drill holes on inside face of front grain cart leg.

Run Wire from Left Weigh Spindle through left port and connect to left side terminal.

Connect the J-Box cable between the center terminal and the indicator located on the front of the grain cart leg.

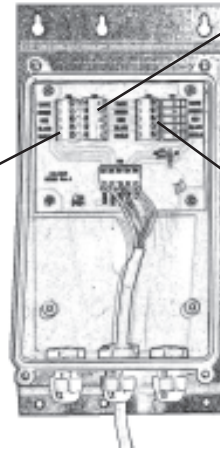

Run Wire from Hitch Weigh Bar through center port and connect to center terminal.

Run Wire from Right Weigh Spindle through right port and connect to right side terminal.

Junction Box Wiring Diagram

+Exc = Red
-Exc = Black
+Sig = White
-Sig = Green
Shield = Orange

MOUNTING THE BATTERY BOX

- Using the Battery Box as a template, mark and drill two 7/16" holes on the inside of the front leg approximately 16" above the A-Frame.
- Secure the Battery Box to the leg of the grain cart using two 3/8" x 1" flange bolt and nuts.

(12V Lawn and Garden Battery is not included)



(Inside View of Front Leg)

Owner Supplied Battery

Battery Box mounted to inside of front leg

Extension Cable (to move Indicator into tractor cab) stored here.

MOUNTING THE INDICATOR

- A mounting bracket is included to mount the indicator to the front leg of the grain cart. Using the mounting bracket as a template, mark and drill 7/16" holes on the front leg of the grain cart approximately 33" above the A-Frame.
- Secure the mounting bracket to the front leg using two 3/8" x 1" flange bolts and nuts. Slide the Indicator across the top of the mounting bracket and secure using two #10 bolts and nuts.
- Connect the J-Box cable to the port on the bottom of the Indicator.

(Note: An extension cord between the J-Box cable and the Indicator is available to mount the Indicator in the tractor cab if desired.)

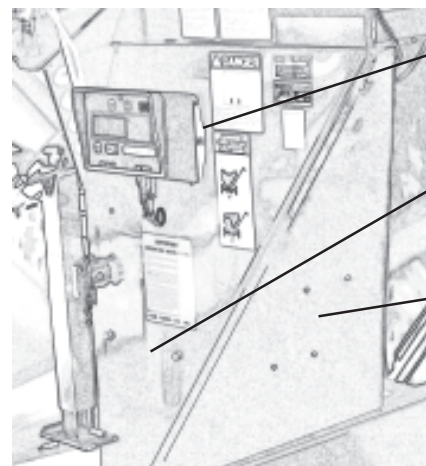

Indicator with Mounting Bracket

Location of Battery Box (inside of panel)

Location of Junction Box (inside of panel)

Installation of Digi-Star Scale System for Models 1050 and 1150 Grain Carts Equipped with Walking Tandem Dual Wheels

CONNECTING THE POWER CORD

- To connect the Power Cord to the Indicator Box, attach screw plug end of the Power Cord into the power port of the Indicator Box. To connect to the battery, secure the Red Wire of the Power Cord to the Positive Terminal of the battery and the Black Wire to the Negative Terminal. Be sure any additional wires provided by the Power Cord are properly stored and secured.

PARTS LIST

#	Part #	Description
1	375WS	3 3/4" Weigh Spindle
2	278WB-T	2 7/8" Hitch Weigh Bar
3	EZ-400S	Indicator with Mounting Plate
3	EZ-3400SP	Indicator with Mounting Plate
4	JB-5	5-Pt Junction Box
5	PC-1	Power Cord to Battery
6	ECI-1	Extension Cord (optional)
7	37605SA	Seal (Hub)
8	ATP-375-GS	4 1/2" OD Adapter Pipe Tubing
9	MBI-1	Mounting Bracket for Indicator
10	WBW-278	2 7/8" Weigh Bar Weldment
11	BB-2	Battery Box with Strap
12	343BWN	3/4" x 3" Bolt (Gr 8) with Heavy Lock Washer and Nut
13	MB-58612	5/8" x 6 1/2" Bolt (Gr 5) with Nut
14	MB-381	3/8" x 1" Bolt with Nut
15	PB-10	#10 Pan Bolt with Nut
16	MB-1434	1/4" x 3/4" Bolt with Nut

NOTE:

When inserting both the weigh spindles or the hitch weigh bar, be sure that the TOP of the spindle is in the upright position as indicated by the decal on each weigh bar.

Failure to correctly align the weigh bar and spindles in the upright position will cause the scale system to read with greater inaccuracy.

