

# OPERATOR'S MANUAL

and Set-Up Instructions for

# GRAVITY BOXES

## 250-7S Gravity Box



## 250-7SB Gravity Box



**J. & M. Mfg. Co., Inc.**

P.O. Box 547 Ft. Recovery, OH 45846

Ph: (419) 375-2376 Fax: (419) 375-2708

[www.jm-inc.com](http://www.jm-inc.com)

JMMAN0101 (Rev. 02/06/09)

**TO THE DEALER:**

Read manual instructions and safety rules. Make sure all items on the Dealer’s Pre-Delivery and Delivery Check Lists in the Operator’s Manual are completed before releasing equipment to the owner.

The dealer must complete the Warranty Registration Card attached to the inside of this manual and return to J. & M. Mfg. Co. Inc. at the address indicated on the card. **Warranty claims will be denied if the Warranty Registration Card has not been completed and returned.**

**EXPRESS WARRANTY:**

J. & M. Mfg. Co. Inc. warrants against defects in construction or materials for a period of ONE year. We reserve the right to inspect and decide whether material or construction was faulty or whether abuse or accident voids our guarantee.

Warranty service must be performed by a dealer or service center authorized by J. & M. Mfg. Co. Inc. to sell and/or service the type of product involved, which will use only new or remanufactured parts or components furnished by J. & M. Mfg. Co. Inc. Warranty service will be performed without charge to the purchaser for parts or labor based on the Warranty Labor Times schedule. Under no circumstance will allowable labor times extend beyond the maximum hours indicated in the Warranty Labor Times schedule for each warranty procedure. The purchaser will be responsible, however, for any service call and/or transportation of the product to and from the dealer or service center’s place of business, for any premium charged for overtime labor requested by the purchaser, and for any service and/or maintenance not directly related to any defect covered under the warranty. Costs associated with equipment rental, product down time, or product disposal are not warrantable and will not be accepted under any circumstance.

Each warranty term begins on the date of product delivery to the purchaser. Under no circumstance will warranty be approved unless (i) the product warranty registration card (attached to the inside of the Operator’s Manual) has been properly completed and submitted to the equipment manufacturer, and (ii) a warranty authorization number has been issued by the equipment manufacturer. This Warranty is effective only if the warranty registration card is returned within 30 days of purchase.

This warranty does not cover a component which fails, malfunctions or is damaged as a result of (i) improper modification or repair, (ii) accident, abuse or improper use, (iii) improper or insufficient maintenance, or (iv) normal wear or tear. This warranty does not cover products that are previously owned and extends solely to the original purchaser of the product. Should the original purchaser sell or otherwise transfer this product to a third party, this Warranty does not transfer to the third party purchaser in any way. J. & M. Mfg. Co. Inc. makes no warranty, express or implied, with respect to tires or other parts or accessories not manufactured by J. & M. Mfg. Co. Inc. Warranties for these items, if any, are provided separately by their respective manufacturers.

**THIS WARRANTY IS EXPRESSLY IN LIEU OF ALL OTHER WARRANTIES OR CONDITIONS, EXPRESS, IMPLIED OR STATUTORY, INCLUDING ANY IMPLIED WARRANTY OF MERCHANTABILITY OR FITNESS FOR PARTICULAR PURPOSE.**

In no event shall J. & M. Mfg. Co. Inc. be liable for special, direct, incidental or consequential damages of any kind. The exclusive remedy under this Warranty shall be repair or replacement of the defective component at J. & M. Mfg. Co. Inc’s. option. This is the entire agreement between J. & M. Mfg. Co. Inc. and the Owner about warranty and no J. & M. Mfg. Co. Inc. employee or dealer is authorized to make any additional warranty on behalf of J. & M. Mfg. Co. Inc.

The manufacturer reserves the right to make product design and material changes at any time without notice. They shall not incur any obligation or liability to incorporate such changes and improvements in products previously sold to any customer, nor shall they be obligated or liable for the replacement of previously sold products with products or parts incorporating such changes.

**SERVICE:**

The equipment you have purchased has been carefully manufactured to provide dependable and satisfactory use. Like all mechanical products, it will require cleaning and upkeep. Lubricate the unit as specified. Observe all safety information in this manual and safety signs on the equipment.

For service, your authorized J. & M. dealer has trained mechanics, genuine J. & M. service parts, and the necessary tools and equipment to handle all your needs.

Use only genuine J. & M. service parts. Substitute parts may void the warranty and may not meet standards required for safe and satisfactory operation. Record the model number and serial number of your equipment in the spaces provided:

**Serial No.:** \_\_\_\_\_ **Date of Purchase:** \_\_\_\_\_

**Purchased From:** \_\_\_\_\_

Provide this information to your dealer to obtain correct repair parts.

## 250-7S GRAVITY BOX

### SPECIFICATIONS

#### DIMENSIONS\*

A)	120"
B)	57 1/2"
C)	79 1/2"
D)	68"
E)	88"
F)	84"
G)	187"
H)	17"

#### DIMENSIONS\*\*

A)	120"
B)	57 1/2"
C)	103"
D)	74"
E)	93"
F)	84"
G)	192"
H)	19"

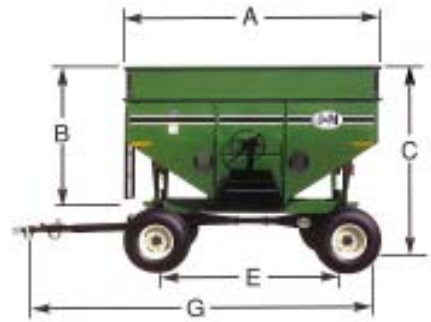

- \* 250-7 Gravity Box, less sides, mounted on 8 Ton Running Gear with 11L-15 Tires.  
 \*\* 250-7 Gravity Box, with sides and rocking bolster, mounted on 10 Ton Running Gear with 12.5L-15 Tires.

### SPECIFICATIONS

Capacity	165 bu or 250 bu (w/sides)
Door Width	30"
Chute Height	15" (w/ model 868 running gear)
Chute Height	23" (w/ model 1074 running gear w/rocking bolster)
Understructure	11 GA 3" x 6" Tubing
Taillights	Standard
Front Ladder	Standard
Hopper Construction	14 GA
Weight	1,020# (250-7 Box only, less sides) 1,760# (250-7 and 868 running gear) 2,260# (250-7, sides, and 1074 running gear w/rocking bolster)

### GENERAL INFORMATION

#### TO THE OWNER:

The purpose of this manual is to assist you in operating and maintaining your gravity box in a safe manner. Read it carefully. It furnishes information and instructions that will help you achieve years of dependable performance and help maintain safe operating conditions. If this machine is used by an employee or is loaned or rented, make certain that the operator(s), prior to operating:

1. Is instructed in safe and proper use.
2. Reviews and understands the manual(s) pertaining to this machine.

Throughout this manual, the term **IMPORTANT** is used to indicate that failure to observe can cause damage to equipment. The terms **CAUTION**, **WARNING** and **DANGER** are used in conjunction with the Safety-Alert Symbol, (a triangle with an exclamation mark), to indicate the degree of hazard for items of personal safety. When you see this symbol, carefully read the message that follows and be alert to the possibility of personal injury or death.



This Safety-Alert symbol indicates a hazard and means **ATTENTION! BECOME ALERT! YOUR SAFETY IS INVOLVED!**



Indicates an imminently hazardous situation that, if not avoided, will result in death or serious injury.



Indicates a potentially hazardous situation that, if not avoided, could result in death or serious injury, and includes hazards that are exposed when guards are removed.



Indicates a potentially hazardous situation that, if not avoided, may result in minor or moderate injury.

**IMPORTANT**

Indicates that failure to observe can cause damage to equipment.

**NOTE**

Indicates helpful information.

## GENERAL INFORMATION

### BOLT TORQUE CHART

Always tighten hardware to these values unless a different torque or tightening procedure is listed for a specific application.

Fasteners must always be replaced with the same grade as specified in the manual parts list.

Always use the proper tool for tightening hardware: SAE for SAE hardware and Metric for metric hardware.

Make sure fastener threads are clean and you start thread engagement properly.

All torque values are given to specifications used on hardware defined by SAE J1701 & J1701M JUL 96.

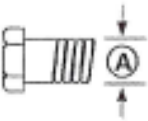

**SAE SERIES  
TORQUE  
CHART**



SAE Bolt Head  
Identification

**SAE Grade 2  
(No Dashes)**



**SAE Grade 5  
(3 Radial Dashes)**



**SAE Grade 8  
(6 Radial Dashes)**

Ⓐ Diameter (Inches)	Wrench Size	MARKING ON HEAD					
		SAE 2		SAE 5		SAE 8	
		Lbs.-Ft.	N-m	Lbs.-Ft.	N-m	Lbs.-Ft.	N-m
1/4	7/16"	6	8	10	13	14	18
5/16	1/2"	12	17	19	26	27	37
3/8	9/16"	23	31	35	47	49	67
7/16	5/8"	36	48	55	75	78	106
1/2	3/4"	55	75	85	115	120	163
9/16	13/16"	78	106	121	164	171	232
5/8	15/16"	110	149	170	230	240	325
3/4	1-1/8"	192	261	297	403	420	569
7/8	1-5/16"	306	416	474	642	669	907
1	1-1/2"	467	634	722	979	1020	1383

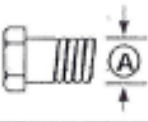

**METRIC SERIES  
TORQUE  
CHART**



Metric Bolt Head  
Identification

**Metric  
Grade 8.8**



**Metric  
Grade 10.9**

Diameter & Thread Pitch (Millimeters)	Wrench Size	COARSE THREAD				FINE THREAD				Diameter & Thread Pitch (Millimeters)
		MARKING ON HEAD				MARKING ON HEAD				
		Metric 8.8		Metric 10.9		Metric 8.8		Metric 10.9		
		N-m	Lbs.-Ft.	N-m	Lbs.-Ft.	N-m	Lbs.-Ft.	N-m	Lbs.-Ft.	
6 x 1.0	10 mm	8	6	11	8	8	6	11	8	6 x 1.0
8 x 1.25	13 mm	20	15	27	20	21	16	29	22	8 x 1.0
10 x 1.5	16 mm	39	29	54	40	41	30	57	42	10 x 1.25
12 x 1.75	18 mm	68	50	94	70	75	55	103	76	12 x 1.25
14 x 2.0	21 mm	109	80	151	111	118	87	163	120	14 x 1.5
16 x 2.0	24 mm	169	125	234	173	181	133	250	184	16 x 1.5
18 x 2.5	27 mm	234	172	323	239	263	194	363	268	18 x 1.5
20 x 2.5	30 mm	330	244	457	337	367	270	507	374	20 x 1.5
22 x 2.5	34 mm	451	332	623	460	495	365	684	505	22 x 1.5
24 x 3.0	36 mm	571	421	790	583	623	459	861	635	24 x 2.0
30 x 3.0	46 mm	1175	867	1626	1199	1258	928	1740	1283	30 x 2.0

## TABLE OF CONTENTS

INTRODUCTION	2
EXPRESS WARRANTY	2
SPECIFICATIONS	3
GENERAL INFORMATION	3
BOLT TORQUE CHART	4
SAFETY RULES	6
SAFETY SIGNS	7
OPERATION	8
ROUTINE MAINTENANCE	8
PARTS LIST/DIAGRAMS	9
LIGHT KIT	10-11
SERVICE RECORDS	12

## **SAFETY RULES**



**ATTENTION! BECOME ALERT! YOUR SAFETY IS INVOLVED!**



Safety is a primary concern in the design and manufacture of our products. Unfortunately, our efforts to provide safe equipment can be erased by an operator's single careless act. In addition, hazard control and accident prevention are dependent upon the awareness, concern, judgement, and proper training of personnel involved in the operation, transport, maintenance and storage of equipment.

Make certain that the operator(s), prior to operating is instructed in safe and proper use and reviews and understands the manual(s) pertaining to this machine.

Read this manual before you operate this machine. If you do not understand any part of this manual, or need more information, contact the manufacturer or your authorized dealer.

### **SAFETY**

Understand that your safety and the safety of other persons is measured by how you service, and operate this machine. Know the positions and functions of all controls before you try to operate them. Make sure to check all controls in a safe area before starting you work.

The safety information given in this manual does not replace safety codes, federal, state or local laws. Make certain your machine has the proper equipment as designated by local laws and regulations.

A frequent cause of personal injury or death is from persons falling off equipment and being run over. Do not permit persons to ride on this machine.

Travel speeds should be such that complete control and machine stability is maintained at all times. Where possible, avoid operating near ditches, embankments and holes. Reduce speed when turning, crossing slopes and rough, slick or muddy surfaces.

Collision of high speed road traffic and slow moving machines can cause personal injury or death. On roads, use flasher lights according to local laws. Keep slow-moving-vehicle emblem visible. Pull over to let faster traffic pass.

Never adjust, service, clean, or lubricate gravity box until all power is shut off.

Keep all safety shields in place.

Keep hands, feet, hair and clothing away from moving parts while unit is in operation.

The service ladder is for service work only. If you must climb into grain tank, be certain that all power is shut off and then use extreme caution when climbing into grain tank.

Never allow anyone in, near or on the gravity box during transporting or unloading grain. Moving grain is dangerous and can cause entrapment, resulting in severe injury or death by suffocation.



Make sure that the gravity box is properly fastened to the running gear.

Make sure that everyone is clear of equipment before applying power to the machinery used in conjunction with the box or when moving the equipment.

Never overload the wagon. Overloading the wagon is dangerous and can cause extensive damage to both the box and running gear. Do not tow loaded gravity box in excess of 20 mph.

Never add more sideboards to the gravity box than what is recommended, as the box is not designed to carry the additional weight.

## SAFETY SIGNS

**ATTENTION! BECOME ALERT! YOUR SAFETY IS INVOLVED!**
  
 Replace Immediately If Damaged or Missing!

**IMPORTANT:** Install new safety signs if the old signs are destroyed, lost, painted over or cannot be read. When parts are replaced that have safety signs, make sure you install a new sign with each new part. New signs are available from the manufacturer or your authorized dealer.

Ref. #	Description	Part #	Req'd
1	Sign, Danger	DD-101	1
2	Sign, Caution	DC-109	1
3	Sign, Important	DI-116	1



DD-101



DC-109



DI-116

## OPERATING INSTRUCTION / MAINTENANCE

### WARNING

**BE CERTAIN THAT ALL POWER IS SHUT OFF BEFORE SERVICING THE GRAVITY BOX.**

Before the gravity box is put into service:

Has the track assembly (opens door) been lubricated for less wear on the sprocket and track and for easier door operation?

Has the SMV (Slow Moving Vehicle) Emblem been positioned with a point of the triangle upward and as near to the rear and centered or as near to the left of center of the unit as practicable? Is it located two to ten feet above the ground measured from the lower edge of the emblem?

Has the gravity box been properly attached to the running gear? If no rocking bolster is used, bolt all four corners (use the 1/2" bolts provided) of the gravity box runners to the running gear. (If the box is used in rough terrain, bolt a minimum of two corners and chain (or cable) the remaining corners to allow more box flexibility).

Have all braces, bolts, nuts, lug bolts, and lug nuts been checked to ensure that they are properly fastened?

Have the safety instructions been read and clearly understood by the operator(s) of this machine?

Do the lights work properly? Are all reflective decals clean and visible? Are they positioned correctly?

### BRAKING SYSTEM REQUIREMENTS

#### WARNING

**For towed equipment WITHOUT brakes, the following is recommended:**

Do NOT tow equipment that does not have brakes at speeds over 32 km/h (20 mph); or that, when fully loaded, has a mass (weight) over 1.5t (3300 lb) and more than 1.5 times the mass (weight) of the towing unit.

**For towed equipment WITH brakes, the following is recommended:**

Do NOT tow equipment that has brakes at speeds over 40 km/h (25 mph); or that, when fully loaded, has a mass (weight) more that 4.5 times the mass (weight) of the towing unit.

#### WARNING

Before filling the gravity box, make certain that no one is inside the grain tank. Never allow children or anyone in, near, or on the gravity box during transport or during loading or unloading of grain. Be aware that moving grain is dangerous and can cause entrapment, resulting in severe injury or death by suffocation.

After hauling corrosive materials such as fertilizers, be sure to wash out the grain tank to prevent premature rusting. Bare spots on metal should be primer coated before applying the outer surface paint.

Check the box periodically for cracks in welds and for other structural damage. Have cracked welds fixed immediately. Failure to do so could result in extensive damage and greatly reduce the life of the gravity box.

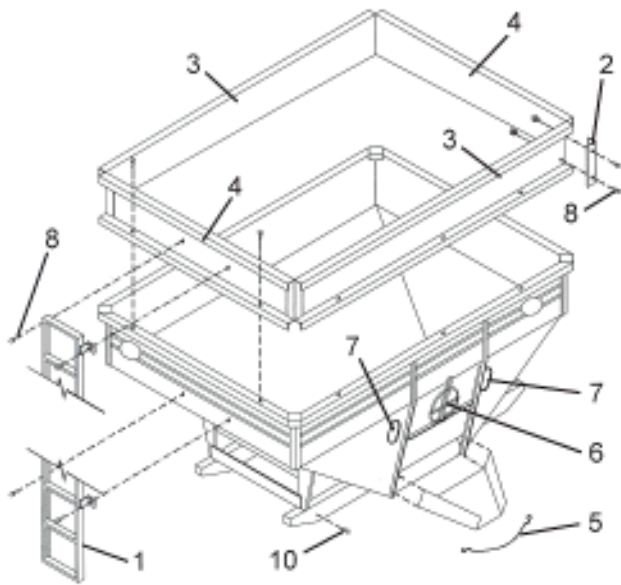

### GRAVITY BOX PARTS LIST

#	Part #	Description	Qty
1	SL-5	Ladder	1
2	C-15	Corner for 15" Boards	4
3	S-1510	Sideboard, 15" x 10'	2
4	E-157	Endboard, 15" x 7'	2
5	TF-21	Chute Fastener, 21"	1
6	CWA-250	Complete Wheel Assembly	1
7	IWK-1	Inspection Window Kit	2
8	381-HBN-F	3/8" x 1" Flange Bolt w/Nut	34
9	381-HBN	3/8" x 1" Bolt w/Nut	2
10	12412BN	1/2" x 4 1/2" Bolt w/Nut	4

### ROCKING BOLSTER ASSEMBLY

#	Part #	Description	Qty
1	URB-250	Upper Rocking Bolster	1
2	LRB-250	Lower Rocking Bolster	1
3	RR-250	Rear Riser	1
4	78BNW	7/8" Bolt w/Nuts, Washers	1
5	38412-BNW	3/8" x 4 1/2" Bolt w/Nuts, Washers	4

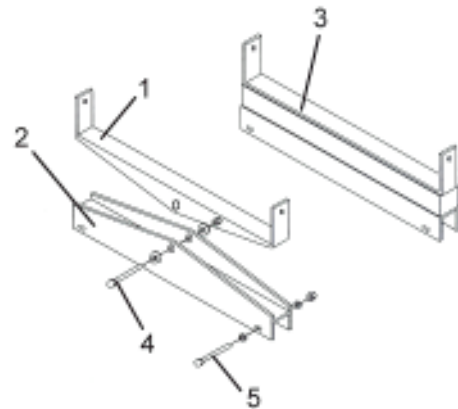

### CHUTE, DOOR AND WHEEL ASSEMBLY

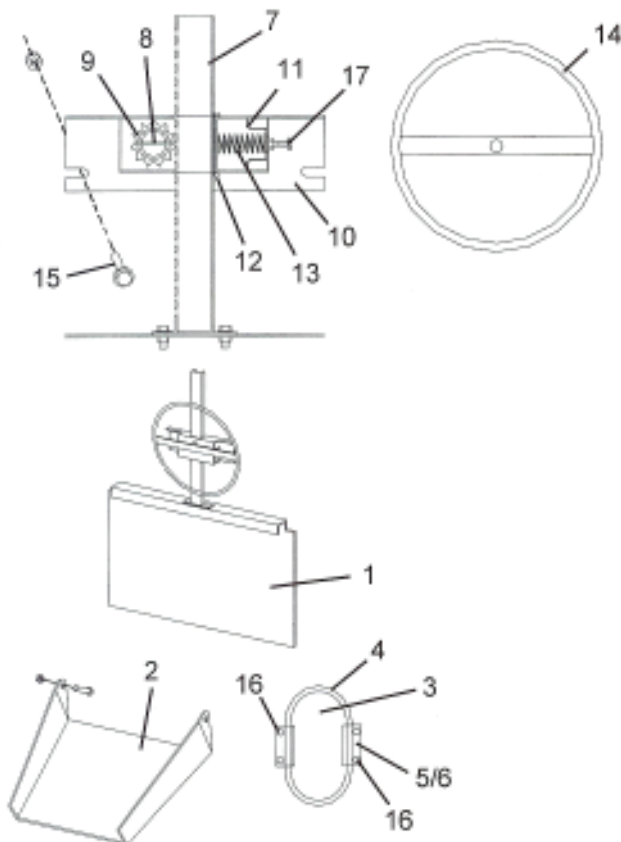

#	Part #	Description	Qty
1	D-250	Door	1
2	GC-30	Grain Chute	1
3	IW-71212	Inspection Window	2
4	62095-7	Window Molding	2
5	WB-4	Window Brace - Inside	4
6	WB-4B	Window Brace - Outside	4
7	TA-2014	Track Assembly	1
8	138RP	1 3/8" Roll Pin	1
9	11T40	11 Tooth Sprocket	1
10	WGA-1034	Welded Guide Assembly	1
11	MC-250	Metal Clip	1
12	GL-250	Galvanized Clip	1
13	DS-250	Door Spring	1
14	WPS-250	Wheel Pin & Strap	1
15	381-HBN-F	3/8" x 1" Bolt w/nut (flange)	4
16	3834-HBN	3/8" x 3/4" Bolt w/nut	8
17	38112BN	3/8" x 1 1/2" Bolt w/nut	1

## GRAVITY BOX LIGHT INSTALLATION GUIDE

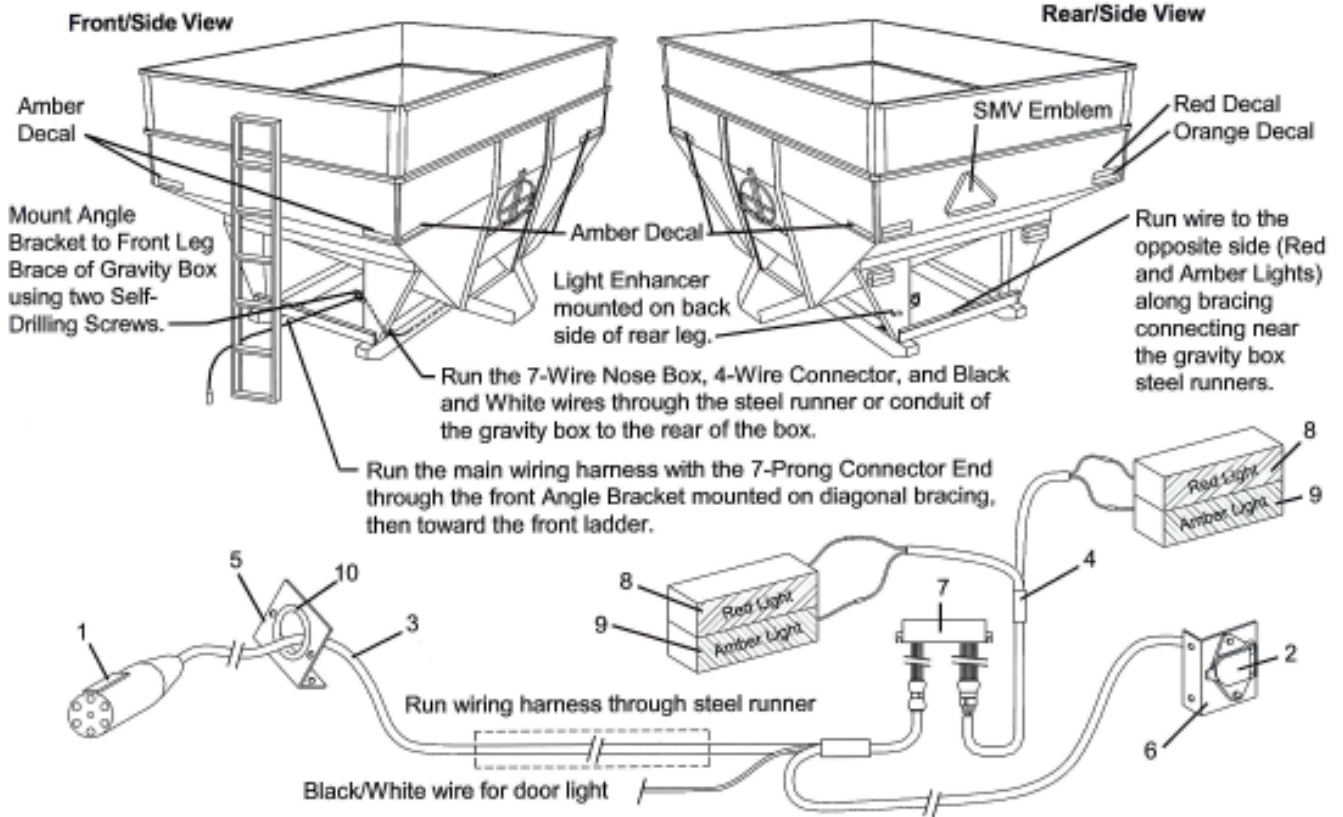

### GRAVITY BOX LIGHT KIT PARTS LIST

#	Part #	Description	Qty
1	7-WCE	7-Wire Connector End	1*
2	7-WNB	7-Wire Nose Box	1*
3	WH-1	Main Wiring Harness	1*
4	LH-1	Light Harness	1
5	AB-1F	Front Angle Bracket	1
6	AB-1R	Rear Angle Bracket	1*
7	LE-1B	Light Enhancer	1
8	LT-R1	Red Light	2
9	LT-A1	Amber Light	2
10	PG-1L	Plastic Grommet	1
11	RD-A1	Amber Reflective Decal	6
12	RD-R1	Red Reflective Decal	2
13	RD-O1	Orange Reflective Decal	2
14	141-CB	1/4" x 1" Carriage Bolt	12
15	14-FN	1/4" Flange Nut	12
16	181-HB	1/8" x 1" Hex Bolt	2
17	18-HN	1/8" Hex Nut	2
18	1434-SDST	1/4" x 3/4" Self-Tapping Screw	7
19	WLC-1	Wire Loom Clamp	3
20	SMV-2	Slow Moving Vehicle Emblem	1
21	WHB-1	Wire Harness Storage Bracket	1
22	RCW-1	Rubber Cap for Bracket	1
23	OFL-1	Flood Light	1
24	OMSC-1	OM Storage Container	1
25	141CB	1/4" x 1" Carriage Bolt	4
26	14WN	1/4" Whiz Nut	4
27	WG-2	Wire Guard for Rear Lights	2
28	RL-1AB	Replacement Lens (amber)	—
29	RL-1RB	Replacement Lens (red)	—

\* Assembled as one unit

**IMPORTANT:** Position the SMV Emblem with a point of the triangle upward and as near to the rear and centered or as near to the left of center of the unit as practicable. The SMV Emblem should be located two to ten feet above the ground measured from the lower edge of the emblem.

#### SECURING THE WIRE HARNESS STORAGE BRACKET

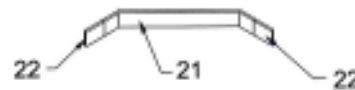

Place the wire harness storage bracket against the front face of the gravity box. Secure the bracket using two 1/4" x 3/4" Self-Tapping Screws. Slide the Rubber End Caps over each end of the Wire Harness Storage Bracket. Securely wrap the Main Wiring Harness around the bracket for storage. To prevent injury, do NOT secure the storage bracket along the side of the ladder.

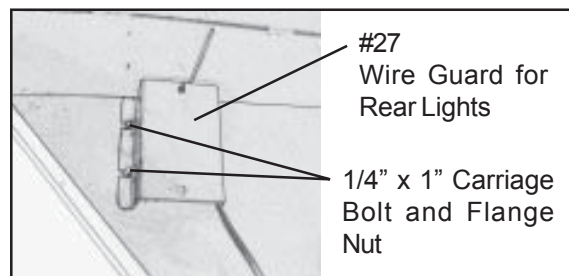

## GRAVITY BOX LIGHT KIT SET UP INSTRUCTIONS:

Mount the Front Angle Bracket to the front diagonal brace of the gravity box using two 1/4" x 3/4" self-tapping screws.

Slide the Main Wiring Harness 7-Prong Connector End through the Front Angle Bracket towards the hitch. The black and white wire and 7-Wire Nose Box on the Main Wiring Harness should run to the rear of the gravity box through either the steel runner or conduit.

Place black Plastic Grommet around the circular cut-out of the Front Angle Bracket.

Secure the 7-Wire Nose Box and Angle Bracket of the Main Wiring Harness back along the runner to the door opening of the gravity box for the optional door light. If the gravity box does not have the optional door light, wrap black and white wire and place inside steel runner of gravity box for storage.

Drill two holes in rear leg of gravity box as shown and secure Light Enhancer on inside face of rear leg using two 1/8" x 1" Hex Bolts and Nuts. (Note: The Light Enhancer should be mounted so the two sets of wire connectors hang from the enhancer box.)

Connect the Main Wiring Harness to the Light Enhancer.

Slide the bolt head of one 1/4" x 1" Carriage Bolt through each of the two slots located on the rear side of each light. The bolt pattern should correspond to the hole pattern on the rear leg of the gravity box. Place the light wire through the hole provided on the rear leg, then slide the bolts through the two holes on the rear leg. Set the Wire Guard on the inside face of the rear leg and secure to the 1/4" x 1" Carriage Bolt using the 1/4" Flange Nut. Repeat for each light. (NOTE: When mounting the red and amber lights to the gravity box, the Red Light should be mounted above the Amber Light on each side.)

Connect Light Wiring Harness to the Light Enhancer and the red and amber lights on the rear leg above. To connect the opposite side red and amber lights, run the Light Wiring Harness along the gravity box bracing connecting the steel runners. Secure the Light Wiring Harness using the three Wire Loom Clamps and Self Tapping Screws.

Place one amber reflective decal at each extreme end of both sides and front of the gravity box as shown. Place one red and one orange reflective decal at each extreme end of the rear of the gravity box as shown. The red decal should be placed above the orange decal.

NOTE: The Front and Rear Angle Brackets are not required on Models 440SD, 540SD, 680SD and 760SD. The Flood Light is optional on Models 250-7S and 385SD.

For J&M Gravity Wagons, Mount the Operator's Manual Storage Container using two 1/4" x 1" Carriage Bolts and 1/4" Flange Nuts to the inside face of the front leg of the gravity wagon as shown (see Figures 1, 2 or 3 below that corresponds to your model of gravity wagon).

Read and Understand all the information in the Operator's Manual BEFORE you operate this machine. Keep the Operator's Manual in the Storage Container and reference the manual as required.

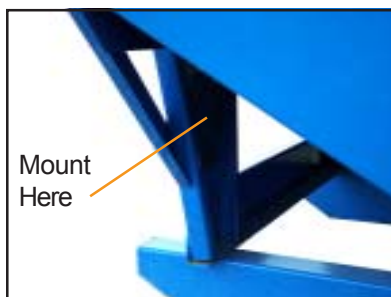

**Model 250-7S**



**Model 385SD**



**Models 440SD, 540SD,  
680SD or 760SD**

