



Trail-Blazer Header Trailers

Commercial Grade Ag and Highway Standard Transports
8,750 Lbs. or 15,700 Lbs. Net Carrying Capacity

ARCHED MAIN FRAME

NEW
HEAVIER
CONSTRUCTION

Designed to Deliver Even More!



TB-3500H or TB-6000H Highway Standard Transport Shown

The new Trail-Blazer models TB-3500 and TB-6000 Series Header Transports are built with a stronger Arched Main Frame to carry your heaviest demands quickly and easily.



Heavier 4" x 8" thick wall steel tubing is used on both the frame and the upper bar to carry larger and heavier heads with less stress.

The front swivel ball axle provides excellent tracking and maneuverability. The rear tandem torsion-flex axles with highway speed rated tires absorb the worst field and road conditions and reduces the stress on both the head and header transport.



Models

TB-3500A

TB-3500H

TB-6000A

TB-6000H



TB-3500A or TB-6000A Ag Standard Transport Shown



Trail-Blazer Header Transports

Models TB-3500A, TB-3500H, TB-6000A and TB-6000H

SPECIFICATIONS

SPECIFICATIONS	TB-3500A	TB-3500H	TB-6000A	TB-6000H
Weight (approx.)	3,280 lbs.	3,280 lbs.	3,500 lbs.	3,500 lbs.
Capacity (Gross)	12,980 lbs.	12,980 lbs.	19,200 lbs.	19,200 lbs.
Capacity (Net)	9,700 lbs.	9,700 lbs.	15,700 lbs.	15,700 lbs.
Spindle Size	Two 2 1/4" dia. (front) Four 2 1/2" dia. (rear)	Two 2 1/4" dia. (front) Four 2 1/2" dia. (rear)	Two 2 1/4" dia. (front) Four 2 1/2" dia. (rear)	Two 2 1/4" dia. (front) Four 2 1/2" dia. (rear)
Hub	6 Bolt	6 Bolt	6 Bolt	6 Bolt
Wheel Size	15" x 6"	15" x 6"	16" x 6"	16" x 6"
Tire Size	225/75R15D	225/75R15D	235/80R16D	235/80R16D
Steel Upper Bar Size	4" x 8"	4" x 8"	4" x 8"	4" x 8"
Upper Bar Length	32', 38', 42' or 48'	32', 38', 42' or 48'	32', 38', 42' or 48'	32', 38', 42' or 48'
Arched Main Frame	4" x 8" x 1/4"	4" x 8" x 1/4"	4" x 8" x 1/4"	4" x 8" x 1/4"
Rear Electric Brakes	Optional	Standard	Optional	Standard
Tie-Down Strap Assembly	Standard	Standard	Standard	Standard
Deluxe Light Package	Ag Standard	Hwy Standard	Ag Standard	Hwy Standard

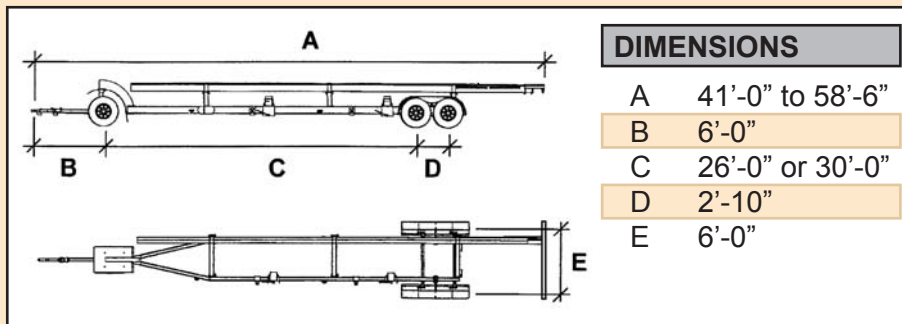

Specifications are subject to change without notice or obligation.

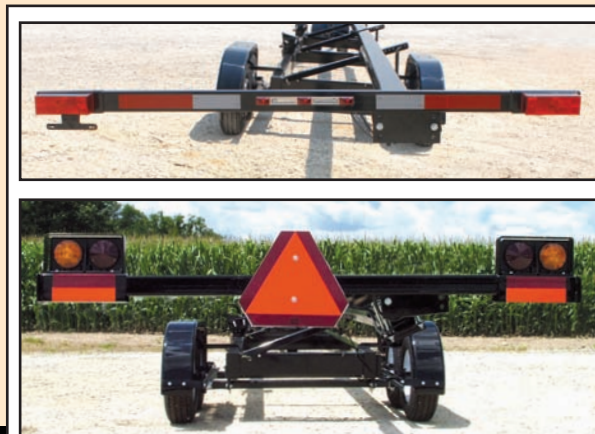

HIGHWAY RATED TRANSPORTS

Models TB-3500H and TB-6000H is manufactured in compliance with the National Association of Trailer Manufacturers and features rear red brake lights and center light bar, 4-wheel electric wheel brakes, breakaway safety brakes, 2 5/16" ball hitch and an owner's title for licensing.

AG RATED TRANSPORTS

Models TB-3500A and TB-6000A is manufactured in compliance with the American Society of Agricultural Engineers and features a telescoping light bar with rear red and amber flashing lights and SMV emblem, standard front clevis or optional 2 5/16" ball hitch, two rear torsion axles with optional electric brakes and optional breakaway safety brakes.

Tool-Less Adjustable Header Mounts and Tie-Down Brackets



J. & M. Mfg. Co., Inc.
 P.O. Box 547 Ft. Recovery, OH 45846
 Ph: (419) 375-2376 Fax: (419) 375-2708
www.jm-inc.com

GUARANTEE

J. & M. MANUFACTURING CO., INC. guarantees against any faulty construction or materials for a period of **ONE** year.
 We reserve the right to inspect and decide whether material or construction was faulty or whether abuse or accident voids our guarantee.